



Pneumatic Power Tools

CATALOGUE



Structure and Working Mechanism of EYP series of oil pulse tools.

The EYP series of oil pulse tools present highest efficiency with simple pulse mechanism.

Pulse unit mainly consists of Cage, Anvil and Piston combined with Roller.

Inside of Anvil, there are a pair of built-in Pistons and Rollers located 180 degrees opposite. There are two mounted portions protruded from the inside wall of Cage, located 180 degrees opposite, also. A pair of Rollers always contact with the inside wall of Cage.

Anvil is installed inside of Cage and is not connected with the air motor, but Cage is directly connected with the air motor. While Anvil is rotating under no load, i.e. free running, Cage rotates together with Anvil. Once Anvil is on load at the snag point, Anvil begins to stop rotating, but Cage still keeps rotating as Cage is directly connected with the air motor.

After Anvil stops rotating, two mounted portions of Cage begin to push a pair of Rollers toward center of Cage, i.e. Rollers start climbing up on the mounts. Oil is fulfilled everywhere inside of Cage and is able to move freely, but this movement of Rollers forces to form a pair of sealed chambers inside of Anvil and possible oil flow will be finally intercepted.

Oil in the sealed chambers keeps compressed as a pair of Rollers are still climbing up on the way. Just before Rollers climb up at the top of the mounts, the seal points between Pistons and Anvil get separated, generating pulse in a moment by releasing energy accumulated in the high pressure oil.

EYP FEATURES

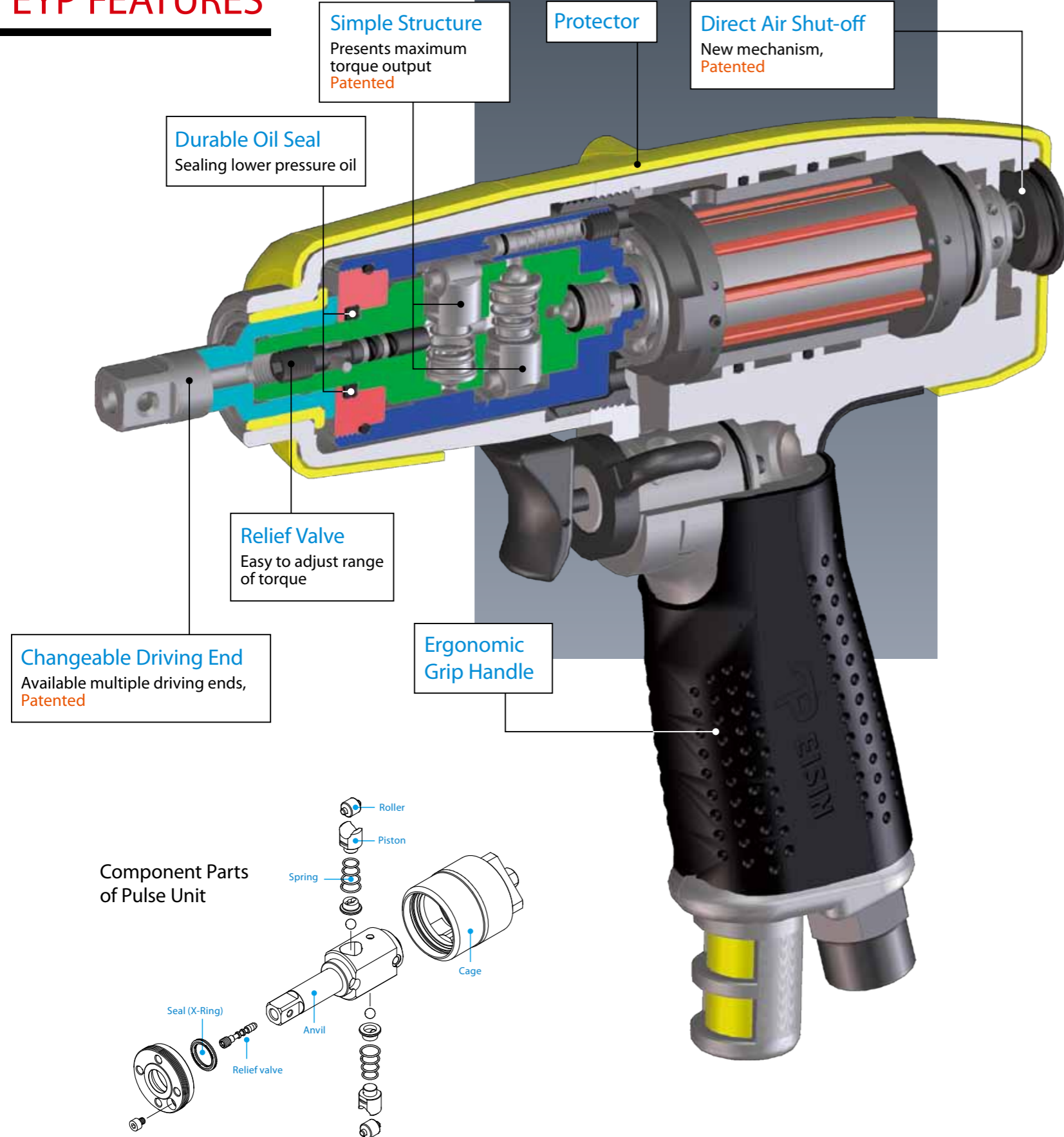

Component Parts of Pulse Unit

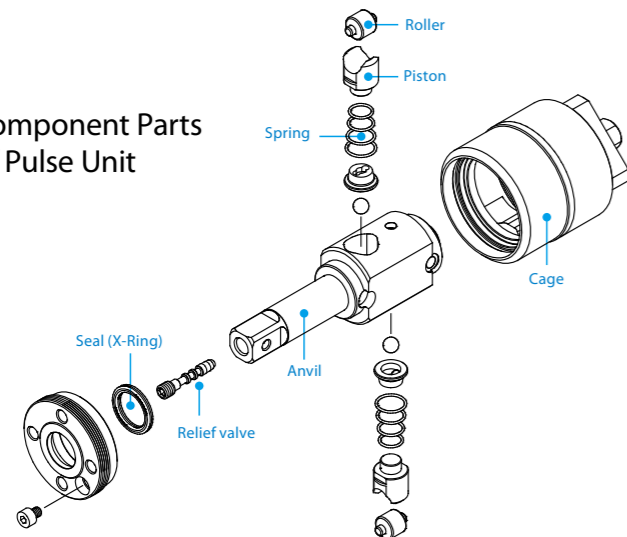

EYP ADVANTAGES

enable to minimize total ownership cost

	Less Initial Cost	Less Running Cost	Ergonomics	Excellent Performance	Easy and Simple Handling
DIRECT AIR SHUT-OFF , patented, makes it possible for EYP pulse tool to provide most accurate and stable shut-off performance despite of possible fluctuation of supply air pressure between 0.4MPa and 0.6MPa.				✓	
SIMPLE STRUCTURE of EYP pulse mechanism, patented, presents maximum torque output, most durable life time, less wearing parts, less overall maintenance cost, as well.		✓		✓	
DURABLE OIL SEAL having two seal-points configuration can offer no oil leakage for a longer overall service life at less expensive replacement cost; same material adopted as ordinary O-ring.		✓			
Diesel engine oil, popularly available in the market, used for EYP pulse tool enables less expensive oil replacement cost.		✓			
CHANGEABLE DRIVING END of EYP pulse tool, patented, enables less reserve cost of backup tools.		✓			✓
Simplified method of oil replacement available for EYP pulse tool enables quick oil change service without using vacuum pump system.		✓			✓
Easy change positioning of RELIEF VALVE , located in the center of EYP pulse tool, enables less time period for adjustment to meet target torque.					✓
Less reaction force from EYP pulse tool combined with ERGONOMIC GRIP HANDLE provides operator friendly handling and less fatigue to the operator's wrist, arm and shoulder.			✓		
Declared values of EYP pulse tools regarding noise level and vibration meet harmonized standards specified in compliance with EC Declaration of Conformity.			✓		
Competitive tool pricing of EYP pulse tools enables to save customer's investment cost.	✓				

HOW DOES THE EYP PULSE TOOL WORK WHILE SUPPLY AIR PRESSURE FLUCTUATES ?

The unique design of EYP pulse tool, combining pulse unit and air shut-off mechanism, provides the most excellent accuracy of shut-off torque while supply air pressure fluctuates between 0.4 MPa and 0.6 MPa or more. While generating pulse, some amount of high pressure oil is going through the internal oil passage (tunnel) in the wall of the anvil and flows into the oil chamber through the check valve orifice. During a series of pulse, accumulated volume of oil in the chamber keeps increasing and finally activates the shutoff piston. When the supply air pressure goes down, the rotation of the air motor slows down and simultaneously, the number of pulse being generated becomes lower, also. As

a result, it takes more time to build up enough fluid pressure to activate the shut-off piston which will transmit fluid force to the air shut-off valve by way of the signal pin located in the center of the rotor. This automatic self-controlled mechanism is called "DIRECT AIR SHUT-OFF", and it is patented. Amount of oil accumulated in the chamber varies in proportion with the energy per pulse as well as the number of pulse. Illustration on the right shows how stably shut-off torque can be maintained even if the supply air pressure fluctuates between 0.4 MPa and 0.6 Mpa.

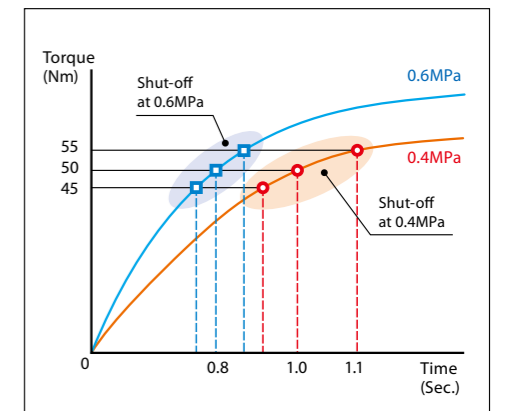

EYP WORKING PRINCIPLE



Mounted portion protruded from inside wall of cage.

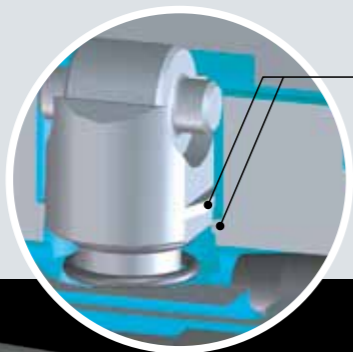

Sealing land of piston not yet get connected with counter seal point of anvil, i.e. oil flows freely in between.

Two mounted portions in the cage begin to push a pair of rollers together with pistons towards center of cage.

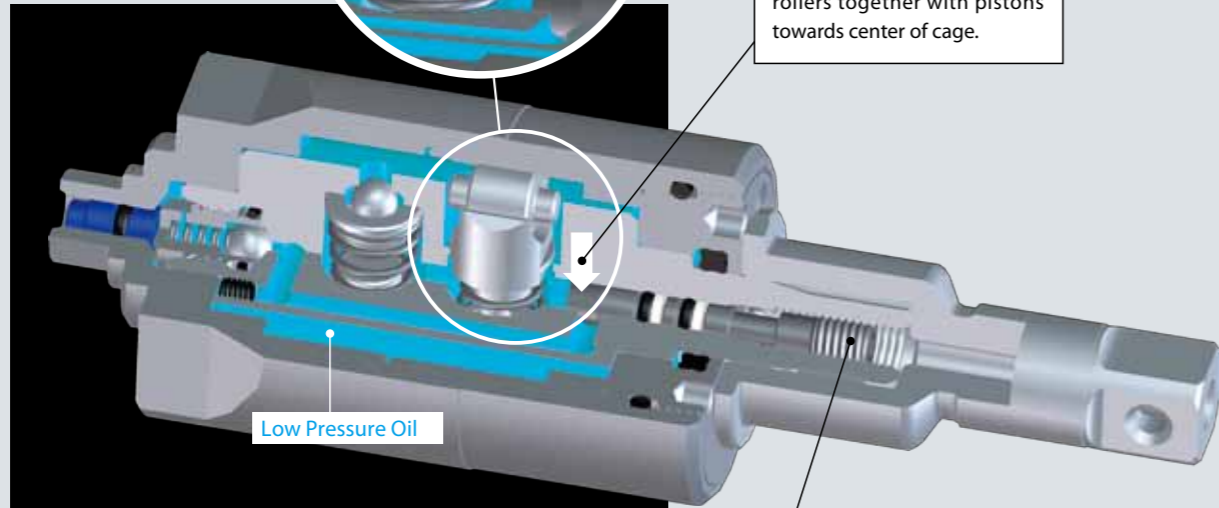

Low Pressure Oil

By changing positioning of relief valve, pressure of oil flowing inside of anvii can be adjusted to control output power of pulse as well as transmitting force to activate shut-off valve.

Cage which is directly connected with rotor of air motor always keeps rotating.

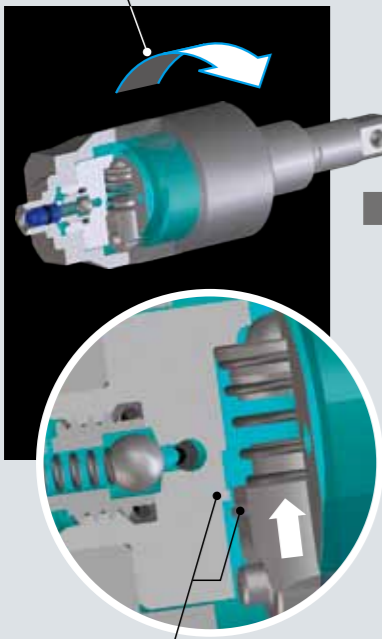

Sealing land of piston not yet get connected with counter seal point of anvil i.e. oil flows freely in between.

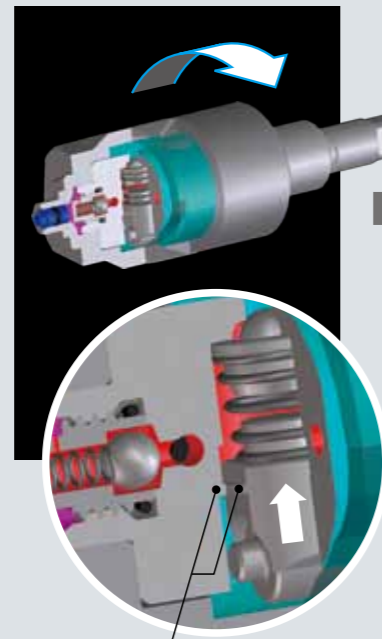

Sealing land of piston reaches counter seal point of anvil and forms sealed chamber in the anvil. Oil in the chamber becomes compressed and generates power of pulse.

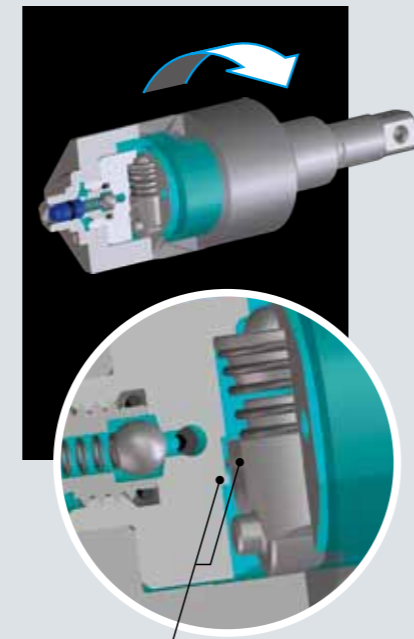

After roller together with pistons go over the mounted portions in the cage, each sealing land becomes disconnected and sealed chambers will disappear.

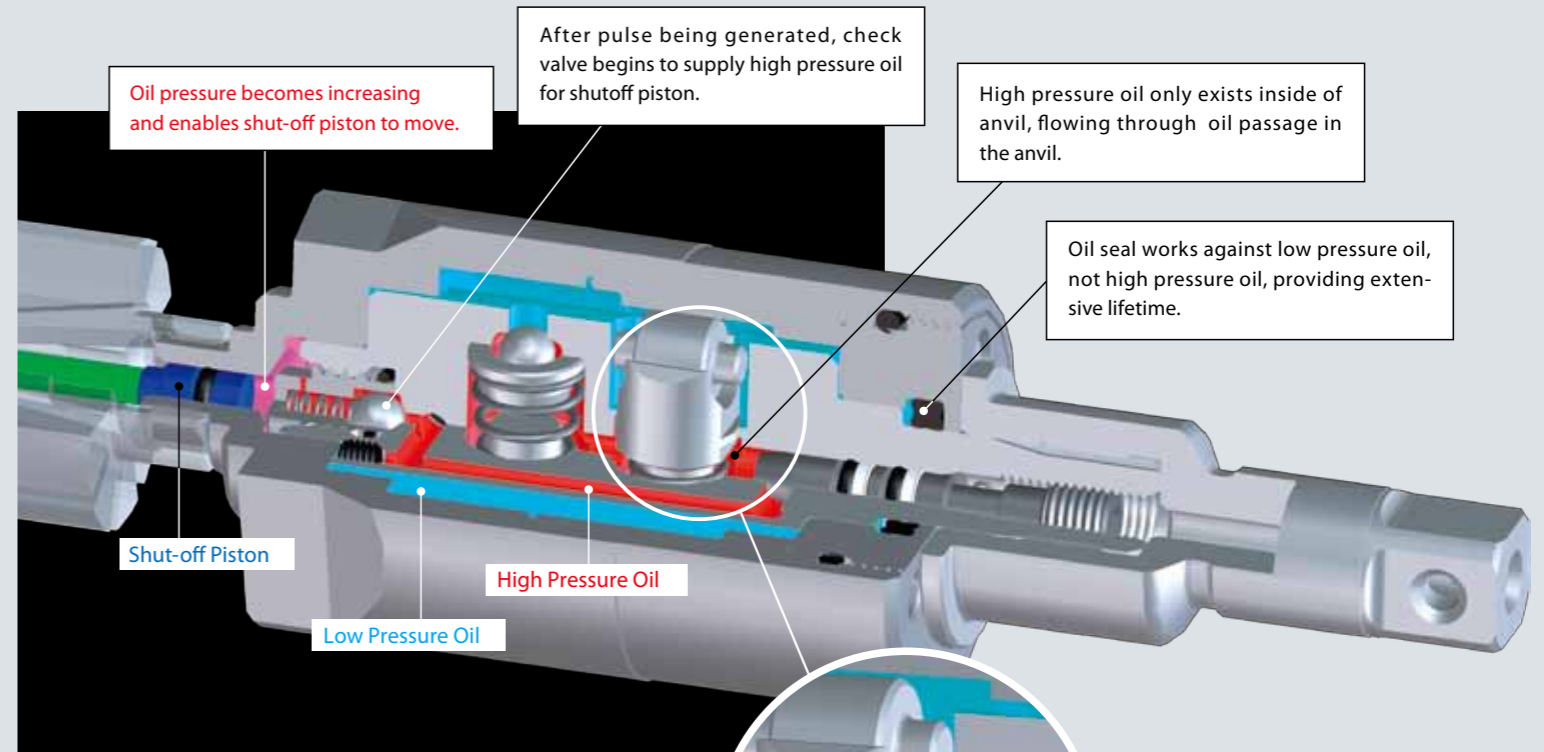

Oil pressure becomes increasing and enables shut-off piston to move.

After pulse being generated, check valve begins to supply high pressure oil for shutoff piston.

High pressure oil only exists inside of anvil, flowing through oil passage in the anvil.

Oil seal works against low pressure oil, not high pressure oil, providing extensive lifetime.

Shut-off Piston

High Pressure Oil

Low Pressure Oil

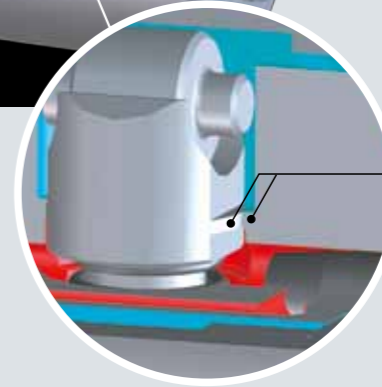

Sealing land of piston gets connected with counter seal point of anvil and forms sealed chamber in the anvil.

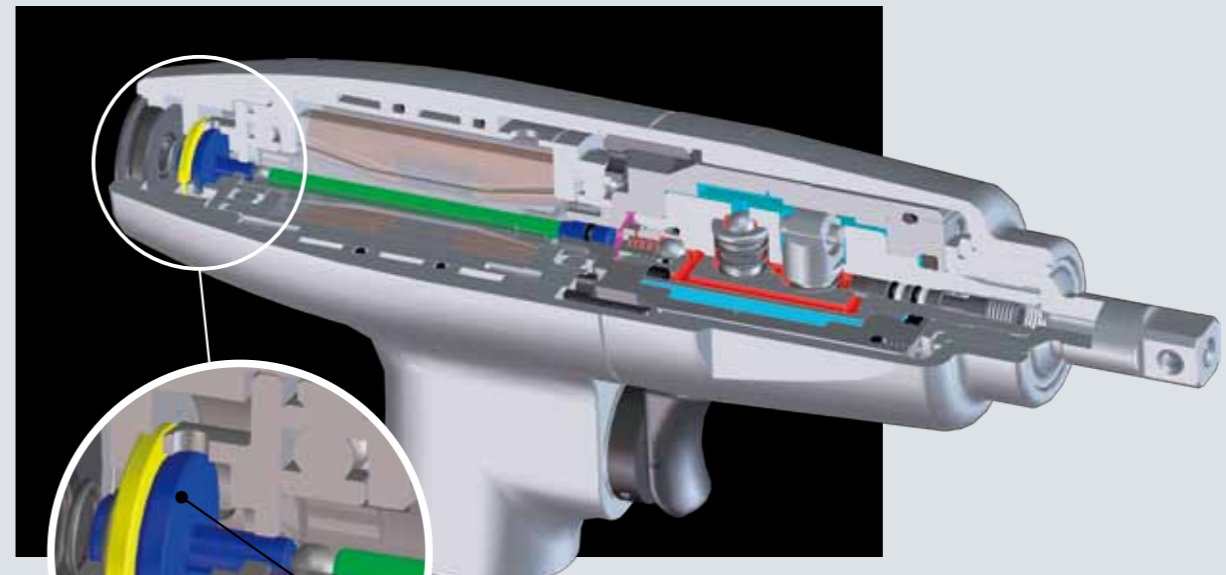

Direct Shut-off Mechanism (Patented)

When fastening torque reaches preset torque,
 Shut-off piston pushes signal pin.
 Signal pin pushes shut-off valve, then air supply will be shut off.

Tool Selection Guide

Helps to select appropriate EYP tool model for your fastening application. Actual torque values may vary depending on the application and tightening conditions on the job site. It is recommended to use this guide as a reference.

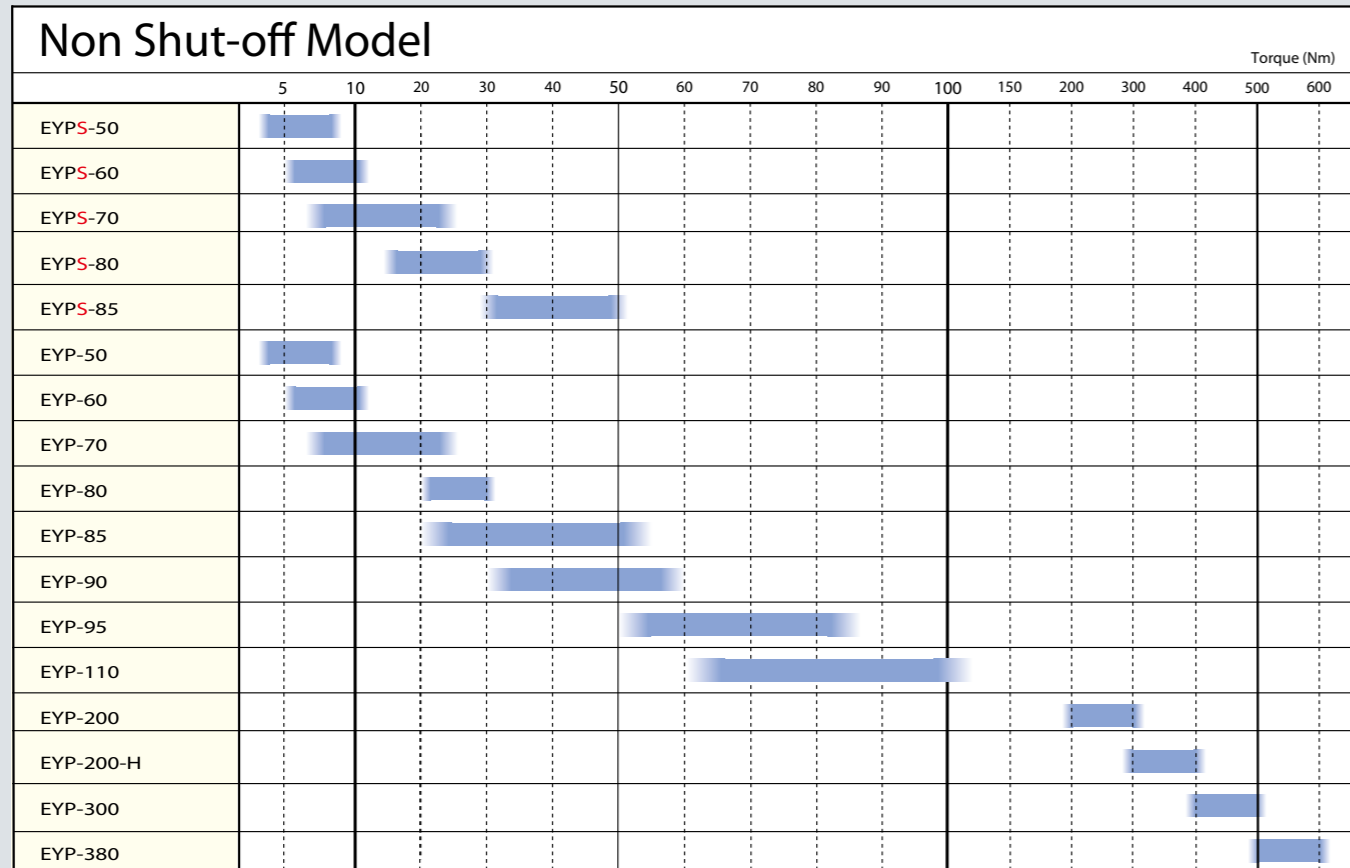
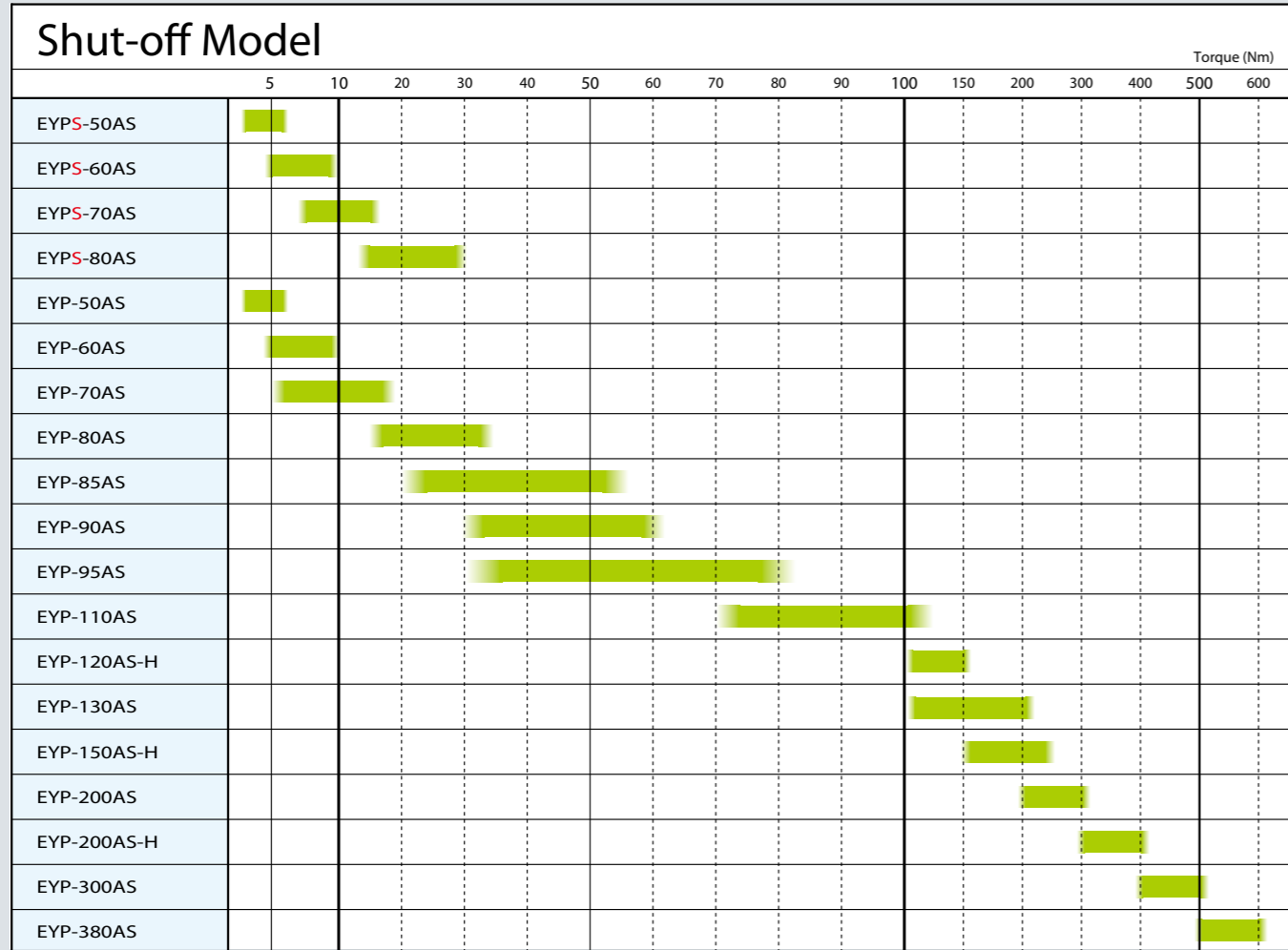

Oil Pulse Wrench

Shut-off Model

Pistol Grip



SPECIFICATIONS

Model Name	Bolt Size	Torque Range		Size of Driving End		I.D of Hose	Weight	RPM under no load		Average Air Consumption
		0.6 MPa	0.4 MPa	mm	inch			0.4 MPa	0.6 MPa	
EYP-50AS-D	M4 - M6	2.5 - 5.5 Nm	2.5 - 5.5 Nm	6.35 Hex	1/4 Hex	8.5	0.9	8,200	8,400	0.2
EYP-60AS (3/8)	M5 - M6	4.5 - 10 Nm	4.5 - 10 Nm	9.5	3/8	8.5	1.1	7,500	7,800	0.25
EYP-60AS-D	M5 - M6	4.5 - 10 Nm	4.5 - 10 Nm	6.35 Hex	1/4 Hex	8.5	1.1	7,500	7,800	0.25
EYP-70AS (3/8)	M6 - M8	7 - 20 Nm	5 - 18 Nm	9.5	3/8	8.5	1.1	8,000	8,800	0.25
EYP-70AS (1/2)	M6 - M8	7 - 20 Nm	5 - 18 Nm	12.7	1/2	8.5	1.1	8,000	8,800	0.25
EYP-70AS-D	M6 - M8	7 - 20 Nm	5 - 18 Nm	6.35 Hex	1/4 Hex	8.5	1.1	8,000	8,800	0.25
EYP-80AS (3/8)	M6 - M8	18 - 35 Nm	15 - 33 Nm	9.5	3/8	8.5	1.1	7,300	8,000	0.25
EYP-80AS (1/2)	M6 - M8	18 - 35 Nm	15 - 33 Nm	12.7	1/2	8.5	1.1	7,300	8,000	0.25
EYP-80AS-D	M6 - M8	18 - 35 Nm	15 - 33 Nm	6.35 Hex	1/4 Hex	8.5	1.1	7,300	8,000	0.25
EYP-85AS (3/8)	M10 - M12	25 - 60 Nm	20 - 55 Nm	9.5	3/8	8.5	1.1	7,300	8,000	0.25
EYP-85AS (1/2)	M10 - M12	25 - 60 Nm	20 - 55 Nm	12.7	1/2	8.5	1.1	7,300	8,000	0.25
EYP-90AS (3/8)	M10 - M12	33 - 65 Nm	30 - 60 Nm	9.5	3/8	8.5	1.4	5,000	5,500	0.35
EYP-90AS (1/2)	M10 - M12	33 - 65 Nm	30 - 60 Nm	12.7	1/2	8.5	1.4	5,000	5,500	0.35
EYP-90AS-D	M10 - M12	30 - 50 Nm	25 - 45 Nm	6.35 Hex	1/4 Hex	8.5	1.4	5,000	5,500	0.35
EYP-95AS	M10 - M12	30 - 85 Nm	30 - 80 Nm	12.7	1/2	8.5	1.5	4,700	5,100	0.35
EYP-110AS	M12 - M14	70 - 120 Nm	70 - 120 Nm	12.7	1/2	8.5	1.84	4,100	4,600	0.38
EYP-120AS-H	M14	100 - 150 Nm	100 - 150 Nm	12.7	1/2	8.5	2.7	3,000	3,500	0.37
EYP-130AS	M16	120 - 210 Nm	110 - 210 Nm	19	3/4	8.5	3.0	3,300	3,500	0.38
EYP-150AS-H	M16	160 - 280 Nm	160 - 250 Nm	19	3/4	9.5	4.1	2,300	2,600	0.48

※ Air consumption data was taken at air pressure 0.4MPa on load

Oil Pulse Wrench

Shut-off Model

Straight Grip



SPECIFICATIONS

Model Name	Bolt Size	Torque Range		Size of Driving End		I.D of Hose	Weight	RPM under no load		Average Air Consumption
		0.6 MPa	0.4 MPa	mm	inch			0.4 MPa	0.6 MPa	
EYPS-50AS-D	M4 - M5	2.5 - 5.5 Nm	2.5 - 5.5 Nm	6.35 Hex	1/4 Hex	8.5	0.9	5,400	6,100	0.2
EYPS-60AS	M5 - M6	4.5 - 10 Nm	4.5 - 10 Nm	9.5	3/8	8.5	1.0	4,800	5,400	0.2
EYPS-60AS-D	M5 - M6	4.5 - 10 Nm	4.5 - 10 Nm	6.35 Hex	1/4 Hex	8.5	1.0	4,800	5,400	0.2
EYPS-70AS	M6 - M8	7 - 18 Nm	7 - 16 Nm	9.5	3/8	8.5	1.0	4,800	5,400	0.25
EYPS-70AS-D	M6 - M8	7 - 18 Nm	7 - 16 Nm	6.35 Hex	1/4 Hex	8.5	1.0	4,800	5,400	0.25
EYPS-80AS	M6 - M8	15 - 30 Nm	13 - 30 Nm	9.5	3/8	8.5	1.0	4,800	5,400	0.25
EYPS-80AS-D	M6 - M8	15 - 30 Nm	13 - 30 Nm	6.35 Hex	1/4 Hex	8.5	1.0	4,800	5,400	0.25

※Air consumption data was taken at air pressure 0.4MPa on load

Straight Grip



SPECIFICATIONS

Model Name	Bolt Size	Torque Range		Size of Driving End		I.D of Hose	Weight	RPM under no load		Average Air Consumption
		0.6 MPa	0.4 MPa	mm	inch			0.4 MPa	0.6 MPa	
EYP-200AS	M18 - M20	200 - 300 Nm	200 - 300 Nm	19	3/4	9.5	7.9	3,500	4,000	0.37
EYP-200AS-H	M18 - M20	300 - 400 Nm	300 - 400 Nm	19	3/4	9.5	7.9	3,500	4,000	0.37
EYP-300AS	M20 - M22	400 - 500 Nm	400 - 500 Nm	25.4	1	12.7	10.3	4,200	4,800	0.41
EYP-380AS	M20 - M22	500 - 600 Nm	500 - 600 Nm	25.4	1	12.7	10.7	3,300	4,000	0.59

※Air consumption data was taken at air pressure 0.4MPa on load

Oil Pulse Wrench

Non Shut-off Model

Pistol Grip



SPECIFICATIONS

Model Name	Bolt Size	Torque Range		Size of Driving End		I.D of Hose	Weight	RPM under no load		Average Air Consumption
		0.6 MPa	0.4 MPa	mm	inch			0.4 MPa	0.6 MPa	
EYP-50-D	M4 - M5	4 - 10 Nm	3 - 8 Nm	6.35 Hex	1/4 Hex	8.5	0.95	6,800	6,400	0.25
EYP-60 (3/8)	M5 - M6	8 - 15 Nm	5 - 12 Nm	9.5	3/8	8.5	1.0	6,700	7,000	0.28
EYP-60-D	M5 - M6	8 - 15 Nm	5 - 12 Nm	6.35 Hex	1/4 Hex	8.5	1.0	6,700	7,000	0.28
EYP-70 (3/8)	M6 - M8	10 - 30 Nm	7 - 25 Nm	9.5	3/8	8.5	1.0	8,500	9,500	0.3
EYP-70-D	M6 - M8	10 - 30 Nm	7 - 25 Nm	6.35 Hex	1/4 Hex	8.5	1.0	8,500	9,500	0.3
EYP-80 (3/8)	M6 - M8	25 - 35 Nm	20 - 30 Nm	9.5	3/8	8.5	1.0	8,500	9,500	0.3
EYP-80 (1/2)	M6 - M8	25 - 35 Nm	20 - 30 Nm	12.7	1/2	8.5	1.0	8,500	9,500	0.3
EYP-80-D	M6 - M8	25 - 35 Nm	20 - 30 Nm	6.35 Hex	1/4 Hex	8.5	1.0	8,500	9,500	0.3
EYP-85 (3/8)	M10 - M12	35 - 65 Nm	30 - 60 Nm	9.5	3/8	8.5	1.0	8,500	9,500	0.25
EYP-85 (1/2)	M10 - M12	35 - 65 Nm	30 - 60 Nm	12.7	1/2	8.5	1.0	8,500	9,500	0.25
EYP-90 (3/8)	M10 - M12	35 - 70 Nm	30 - 65 Nm	9.5	3/8	8.5	1.35	4,900	5,300	0.35
EYP-90 (1/2)	M10 - M12	35 - 70 Nm	30 - 65 Nm	12.7	1/2	8.5	1.35	4,900	5,300	0.35
EYP-95	M10 - M12	60 - 95 Nm	50 - 85 Nm	12.7	1/2	8.5	1.35	4,900	5,300	0.35
EYP-110	M12 - M14	80 - 140 Nm	60 - 120 Nm	12.7	1/2	8.5	1.6	4,200	4,700	0.35

※Air consumption data was taken at air pressure 0.4MPa on load

Straight Grip



SPECIFICATIONS

Model Name	Bolt Size	Torque Range		Size of Driving End		I.D of Hose	Weight	RPM under no load		Average Air Consumption
		0.6 MPa	0.4 MPa	mm	inch			0.4 MPa	0.6 MPa	
EYPS-50-D	M4 - M5	4 - 10 Nm	3 - 8 Nm	6.35 Hex	1/4 Hex	8.5	0.95	6,500	7,000	0.23
EYPS-60 (3/8)	M5 - M6	8 - 15 Nm	5 - 12 Nm	9.5	3/8	8.5	0.95	4,700	5,000	0.26
EYPS-60-D	M5 - M6	8 - 15 Nm	5 - 12 Nm	6.35 Hex	1/4 Hex	8.5	0.95	4,700	5,000	0.26
EYPS-70 (3/8)	M6 - M8	10 - 30 Nm	7 - 25 Nm	9.5	3/8	8.5	0.95	4,700	5,000	0.26
EYPS-70-D	M6 - M8	10 - 30 Nm	7 - 25 Nm	6.35 Hex	1/4 Hex	8.5	0.95	4,700	5,000	0.26
EYPS-80 (3/8)	M6 - M8	20 - 35 Nm	15 - 30 Nm	9.5	3/8	8.5	0.95	4,700	5,000	0.26
EYPS-80-D	M6 - M8	20 - 35 Nm	15 - 30 Nm	6.35 Hex	1/4 Hex	8.5	0.95	4,700	5,000	0.2
EYPS-85 (3/8)	M10 - M12	35 - 55 Nm	30 - 50 Nm	9.5	3/8	8.5	0.95	5,000	5,200	0.2
EYPS-85 (1/2)	M10 - M12	35 - 55 Nm	30 - 50 Nm	12.7	1/2	8.5	0.95	5,000	5,200	0.26
EYP-200	M18 - M20	200 - 300 Nm	200 - 300 Nm	19	3/4	9.5	7.2	3,500	4,000	0.37
EYP-200-H	M18 - M20	300 - 400 Nm	300 - 400 Nm	19	3/4	9.5	7.2	3,500	4,000	0.37
EYP-300	M20 - M22	400 - 500 Nm	400 - 500 Nm	25.4	1	12.7	9.5	4,200	4,800	0.41
EYP-380	M20 - M22	500 - 600 Nm	500 - 600 Nm	25.4	1	12.7	9.8	3,300	4,000	0.59

※Air consumption data was taken at air pressure 0.4MPa on load

POKAYOKE (Fool Proof) System

Air Pressure Detecting Type

POKAYOKE (fool proof) system detects supply air pressure inside the air motor and correctly counts down the number of bolts or nuts fastened. Once bolts or nuts are not fastened accidentally, POKAYOKE display alarms by changing color from green to red. Buzzer to alarm erroneous fastening is available as an option, as well.



Compatible Models

Model Name	Bolt Size
EYP-50AS-PY-D	M4 - M5
EYP-60AS-PY (3/8)	M5 - M6
EYP-60AS-PY-D	M5 - M6
EYP-70AS-PY (3/8)	M6 - M8
EYP-70AS-PY (1/2)	M6 - M8
EYP-70AS-PY-D	M6 - M8
EYP-80AS-PY (3/8)	M6 - M8
EYP-80AS-PY (1/2)	M6 - M8
EYP-80AS-PY-D	M6 - M8
EYP-85AS-PY (3/8)	M10 - M12
EYP-85AS-PY (1/2)	M10 - M12
EYP-90AS-PY (3/8)	M10 - M12
EYP-90AS-PY (1/2)	M10 - M12
EYP-90AS-PY-D	M10 - M12
EYP-95AS-PY	M10 - M12
EYP-120AS-PY	M14
EYP-120AS-H-PY	M14
EYP-150AS-PY	M16
EYP-150AS-H-PY	M16

Model Name	Bolt Size
EYPS-50AS-PY-D	M4 - M5
EYPS-60AS-PY (3/8)	M5 - M6
EYPS-60AS-PY-D	M5 - M6
EYPS-70AS-PY (3/8)	M6 - M8
EYPS-70AS-PY-D	M6 - M8
EYPS-80AS-PY (3/8)	M6 - M8
EYPS-80AS-PY-D	M6 - M8
EYP-200AS-PY	M18 - M20
EYP-200AS-H-PY	M18 - M20
EYP-300AS-PY	M20 - M22
EYP-380AS-PY	M20 - M22

Model Name	Bolt Size
EYI-160T-PY	M16



FEATURES

- To be used with PY model tools.
- Counts down and displays balance due numbers of bolts or nuts to be fastened after the pulse tool shuts off.
- Monitors four different works with different numbers of bolts or nuts to be fastened.
- Alarms on the display if the bolts or nuts are not fastened accidentally.
- Becomes active in right hand rotation for tightening bolts or nuts.
- Becomes inactive in left hand rotation for loosening bolts or nuts.
- Becomes inactive during free running.
- Easy to set up parameter on the front panel.
- Either one of the English or Chinese language can be selected on the display.

SPECIFICATION

- Power Source : 100-240 VAC 50-60 h
- Power Consumption : 1amp @ 115 VAC
- Operating Conditions : 0 to +50°C
- Humidity : 0 to 95% non-condensing
- Weight : 3.1kg
- Approximately Dimensions : 227(L) × 155(W) × 155(H) (mm)

Wireless Type



FEATURES

- Eliminates missing bolts.
- Counts down only a tool shut-off protecting from premature trigger release.
- Possible to stop whole operation or conveyor line using solenoid valve attachment as an option.
- Caution message automatically appears on the monitor and alerts maintenance service or oil replacement due for a tool based on the number of rundowns or cycles.
- Mobile tablet available for monitoring.
- Capable to track and monitor daily and total count graph.
- User friendly programming, easy to customize.
- Language selection.
- Outputs for lights and alarms.
- Compact and light weight pokayoke box.
- Eliminates air tube for signal transfer.

MONITOR

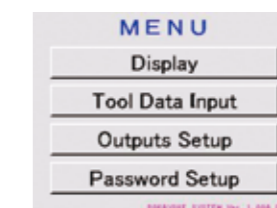

Main menus

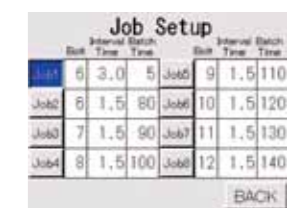

Job Set Up menu up to 8 jobs



OK of Correct Shut-off

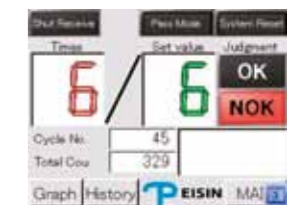

NOK when batch time over

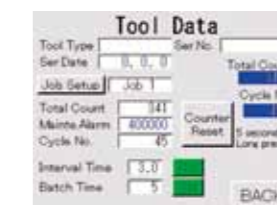

Tool data menu



Daily Tightening Count Graph

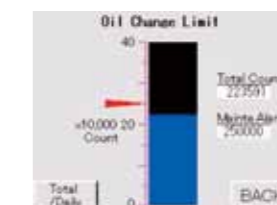

Oil Change warning Graph



Pass Mode Function

Testers

EYT Series

JOINT SIMULATING TESTER



FEATURES

EYT series of Testers are specially designed for the oil pulse tool and are capable of simulating actual fastening application using a bolt and indicate tightening torque values on the digital counter, providing most repeatable and linear joint rate simulation.

It is recommended to use EYP testers before commencing fastening job at every shift change to ensure the torque output of pulse tool.

SPECIFICATIONS

Model Name	Bolt Size	Torque Range	Weight
		Nm	
EYT-6	M4	0.1 ~ 2.7	4.5
	M5	2.7 ~ 5.4	
	M6	5.4 ~ 14.7	
EYT-10	M6	5.4 ~ 14.7	5.5
	M8	14.7 ~ 31.4	
	M10	31.4 ~ 53.9	
EYT-16	M12	53.9 ~ 88.2	11.0
	M14	88.2 ~ 149	
	M16	149 ~ 190	
EYT-24	M18	190 ~ 294	27.0
	M20	294 ~ 441	
	M24	441 ~ 686	

TET Series DIGITAL TORQUE TESTER

TET series of torque testers are specially designed for detecting the maximum torque per blow and the number of blows of oil pulse tool experienced in a preset certain time period.

After a series of usage, performance of the pulse tool may change. TET series of testers are capable of detecting possible changes on the pulse unit and ensure performance at the time. TET series of torque testers are suitable for periodical performance check on the pulse unit.



SPECIFICATIONS

Model Name	Capacity		Accuracy	Size mm(about) (W x D x H)	Weight		Socket Adapter
	Range of torque	Range of blow			Digital Counter	Rundown Fixture	
TET-200	10 - 200 Nm	1 - 99 Hz	±0.55%	W160 x D128 x H108	2.0 kg	6.0 kg	3/8 or 1/2
TET-500	10 - 500 Nm	1 - 99 Hz	±0.55%	W200 x D185 x H116	2.0 kg	18.0 kg	3/4

Digital Counter Specification Size W260 x D180 x H100
Power Source AC 100V

FEATURES

Red colored LED digital counter on the front panel provides visible indication of values.

Easy to engage the digital counter unit with the rundown fixtures; heavy duty and light duty fixtures available.

Easy to connect to optional printer for data recording.

Easy to use, compact, accurate and durable design.

Others

Optimal Torque of Bolt

The optimal torque of bolt is based on the clamp force achieved.

The clamp force applied to bolt should not exceed 70% of the proof load of bolt and the optimal torque applied to bolt should be as much as 60% of the proof load. See the following equation to calculate the optimal torque.

$$T = k \cdot D \cdot N$$

Torque = Coefficient of friction x Nominal Diameter x Clamp Force (Tension)

Property Class	4.8		5.8		6.8		8.8		10.9		12.9	
Nominal Diameter	Torque (Nm)	Proof Load (N)	Torque (Nm)	Proof Load (N)	Torque (Nm)	Proof Load (N)	Torque (Nm)	Proof Load (N)	Torque (Nm)	Proof Load (N)	Torque (Nm)	Proof Load (N)
M3	0.6	1560	0.8	1910	0.9	2210	1.2	2920	1.7	4180	2.0	4880
M4	1.4	2720	1.8	3340	2.0	3860	2.7	5100	4.0	7290	4.6	8520
M5	2.9	4400	3.6	5400	4.1	6250	5.5	8230	8.0	11800	9.4	13800
M6	4.9	6230	6.1	7640	7.0	8840	9.3	11600	13.6	16700	15.9	19500
M8	12.0	11400	14.8	13900	16.9	16100	22.5	21200	33.0	30400	38.7	35500
M10	23.7	18000	29.2	22000	33.4	25500	44.6	33700	65.4	48100	76.6	56300
M12	41.3	26100	51.0	32000	58.3	37100	77.7	48900	114.1	70000	133.5	81800
M14	65.7	35600	81.2	43700	92.7	50600	123.7	66700	181.6	95500	212.5	112000
M16	102.5	48700	126.6	59700	144.7	69100	192.9	91000	283.4	130000	331.6	152000
M18	141.0	59500	174.2	73000	199.1	84500	273.7	115000	389.8	159000	456.2	186000
M20	199.9	76000	247.0	93100	282.2	108000	388.1	147000	552.7	203000	646.8	238000
M22	272.0	93900	336.0	115000	384.0	133000	528.0	182000	751.9	252000	879.9	294000
M24	345.7	109000	427.0	134000	488.0	155000	671.0	212000	955.7	293000	1118.3	342000
M27	505.6	142000	624.6	174000	713.8	202000	981.5	275000	1397.9	381000	1635.9	445000
M30	686.7	174000	848.2	213000	969.4	247000	1332.9	337000	1898.4	466000	2221.6	544000
M33	934.4	215000	1154.3	264000	1319.2	305000	1813.8	416000	2583.4	576000	3023.1	673000

The torque values listed are based on the clamp force (tension) applied to hexagon metric coarse thread bolt and coefficient of friction 0.2 (guidance only).
Select the best tool for your application.

Oil Filler EOF-1



VACUUM PUMP

OIL FILLER

FEATURES

OIL FILLER, EOF-01, offers compact and simple design, providing proper procedures of oil replacement for repair and maintenance of EYP oil pulse tools. Use diesel engine oil, Idemitsu DAPHNE BIOS HIDRO 46SE or equivalent.

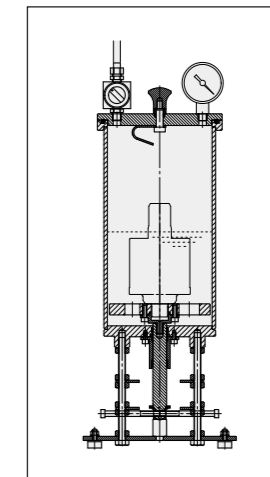

Impact Wrench

Shut-off Model



EYI-160T

FEATURES

Automatically shuts off air supply at the preset target torque, eliminating unnecessary time consuming operation for longer tool life.

Built-in torque control device provides precise reliability.

Easy external torque adjuster provides 24 different steps for adjustment.

Reliable shut-off for minimum torque reaction.

Light weight and compact body.

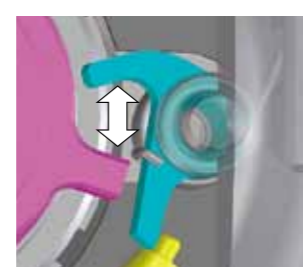

Distance as indicated per illustration can be changed by adjuster. To make distance longer, turn adjuster toward counter-clockwise direction. resulting in higher shut-off torque.



Rebound from the clutch of impact wrench increases in proportion of the tightening torque. At preset target torque, arm kicks valve stopper to automatically active shut-off valve.

SPECIFICATIONS

Model Name	Bolt Size	Torque Range		Size of Square End		I.D of Hose	Weight	RPM under no load		Average Air Consumption
		0.6 MPa	0.4 MPa	mm	inch			mm	kg	
EYI-160T	M16	300 - 380 Nm	230 - 300 Nm	12.7	1/2	8.5	2.8	6,500	7,800	0.38

※Air consumption data was taken at air pressure 0.6MPa on load

Composite Housing Model



ERI-16

ERI-17

FEATURES

Double molded Composite Motor Housing
Produced from Patented Molding System
All made in Japan
Provides Ergonomic Pistol Grip Handle
Less Reaction Force to operator
Realizing ideal Lightweight

Twin Hammer Mechanism
With Oil Bath Clutch
Provides most Durable and Reliable hammering
Eliminating Hammerlock failures

Captured Motor Liner
Ensures Stable and Maximum power output.

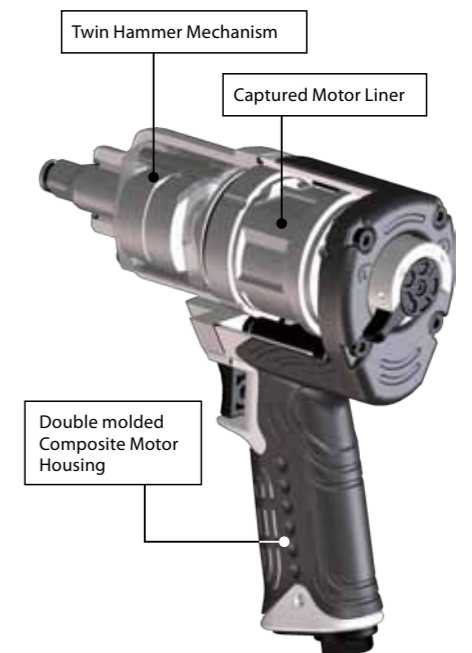

SPECIFICATIONS

Model Name	Bolt Size	Maximum Torque	Size of Square End		I.D of Hose	Weight	RPM under no load	Average Air Consumption
			mm	inch				
ERI-16 (3/8)	M16	450	9.5	3/8	8.5	1.47	10,500	0.5
ERI-16 (1/2)	M16	450	12.7	1/2	8.5	1.47	10,500	0.5
ERI-17	M16	600	12.7	1/2	8.5	2.1	7,600	0.38

※Air consumption data was taken at air pressure 0.6MPa on load

Noise Level and Vibration Value

Noise Level

Values are determined in accordance with EN ISO 15744.2008 using as basic standards EN ISO 3744:2010 and EN ISO 11203:2009

The sum of a measured noise emission value and its associated uncertainty represents an upper boundary of the range of values which is likely to occur in measurement.

Five microphones, MIC1 ~ MIC5, are set as illustrated.

Microphone height above reflecting plane :

MIC1 ~ MIC4 / 1m, MIC5 / 2m

Brake system : Conformed to EN ISO 28937-2:3009

LWA : A-weighted sound power level.

KWA : Uncertainty

LPA : A-weighted emission sound pressure level at work station.

KPA : Uncertainty

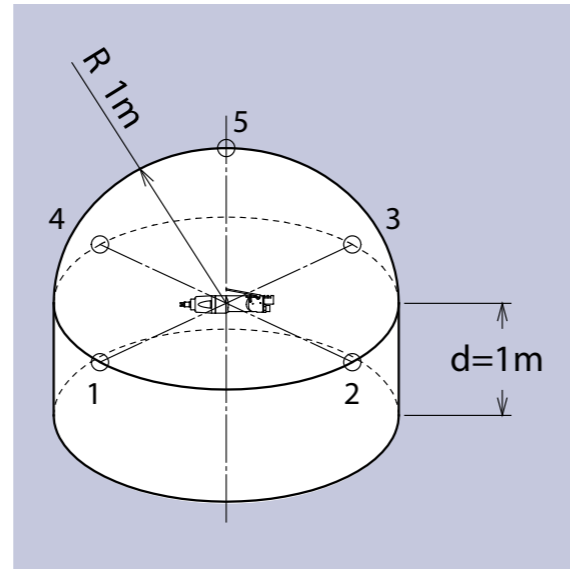

Vibration

Values are measured in accordance with EN ISO 28927-2:2009; Hand-held portable tools – Test method for evaluation of vibration emission – Part2: Wrenches, nut runners and screwdrivers.

Socket : conformed to EN ISO 28927-2:2009 1010-02

Brake material : asbestos free

ahd : Declared vibration emission value

K : uncertainty

The declared values were obtained by laboratory type testing in compliance with the standards and are not adequate for use in risk assessments. Values measured in individual work places may be higher than the declared values. The actual exposure values and risk of harm experienced by an individual user are unique and depend upon the way the user works, work piece and the workstation design, as well as upon the exposure time and the physical condition of the user. We, Eisin Co., Ltd., cannot be held liable for the consequences of using the declared values, instead of values reflecting the actual exposure, in an individual risk assessment in the work place situation over which we have no control.

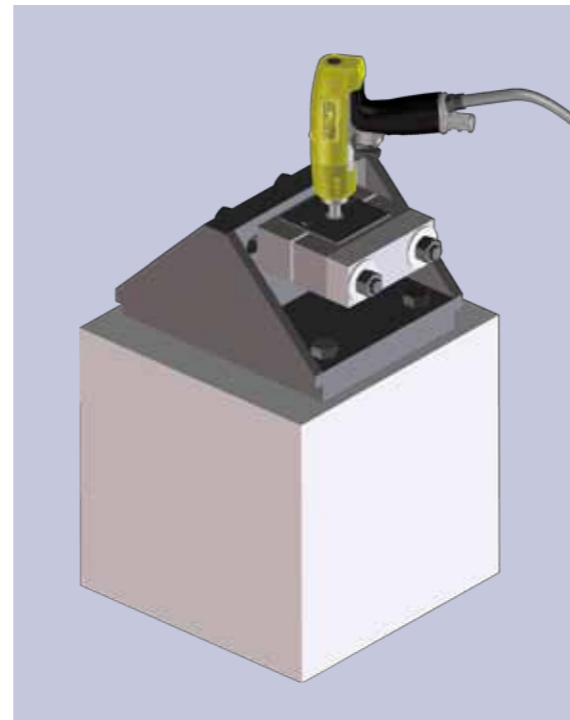

Pulse Wrench

Model Name	ISO 15744		ISO 28927-2 measured under load		Grip Style	Shut-off Style		
	Sound Pressure Level (LpA)	Sound Power Level (LwA)	Vibration Total Value (ahd)	Vibration Uncertainty (K)				
	dB(A)	dB(A)	m/sec ²	m/sec ²				
EYP-50AS	71.09	82.09	0.84	0.58	Pistol Grip	Shut-off		
EYP-60AS	82.23	93.13	0.86	0.58				
EYP-70AS	80.07	91.07	0.86	0.56				
EYP-80AS	79.39	90.39	0.86	0.58				
EYP-85AS	79.91	90.91	1.09	0.60				
EYP-90AS	80.32	91.32	1.65	0.66				
EYP-95AS	81.09	92.09	4.6	0.95				
EYP-110AS	81.31	92.31	3.08	0.79				
EYP-120AS-H	77.42	88.42	6.5	1.14				
EYP-130AS	84.89	95.89	4.3	0.92				
EYP-150AS-H	80.43	91.43	4.4	0.94				
EYPS-50AS	73.46	84.46	1.94	0.68			Straight Grip	Shut-off
EYPS-60AS	76.56	87.56	3.9	0.88				
EYPS-70AS	77.68	88.68	3.8	0.88				
EYPS-80AS	76.42	87.42	2.7	0.76				
EYP-200AS	96.15	107.15	3.0	0.79				
EYP-200AS-H	96.15	107.15	3.9	0.88				
EYP-300AS	89.47	100.47	3.0	0.79				
EYP-380AS	89.57	100.57	4.8	0.97				
EYP-50	70.40	81.40	2.1	0.71	Pistol Grip	Non Shut-off		
EYP-60	82.23	93.23	0.86	0.58				
EYP-70	80.07	91.07	0.86	0.56				
EYP-80	80.42	91.42	2.5	0.74				
EYP-85	79.91	90.91	1.09	0.60				
EYP-90	80.92	91.92	4.5	0.94				
EYP-95	80.71	91.71	3.5	0.84				
EYP-110	81.03	92.03	3.68	0.21				
EYPS-50	76.04	87.04	1.75	0.67			Straight Grip	Non Shut-off
EYPS-60	76.56	87.56	3.9	0.88				
EYPS-70	76.62	87.62	5.8	1.07				
EYPS-80	75.94	86.94	6.3	1.12				
EYPS-85	74.38	85.38	4.4	0.93				

Impact Wrench

Model Name	ISO 15744		ISO 28927-2 measured under load		Grip Style	Shut-off Style
	Sound Pressure Level (LpA)	Sound Power Level (LwA)	Vibration Total Value (ahd)	Vibration Uncertainty (K)		
	dB(A)	dB(A)	m/sec ²	m/sec ²		
EYI-160T	89.97	100.97	6.6	1.15	Pistol Grip	Shut-off
ERI-16	91	102	6.0	1.09		Non Shut-off
ERI-17	93	104	9.4	1.42		

Uncertainty : Kwa,Kpa=3dB(A)

Oil Pulse Wrenches — Dimensions and tolerances of interface to power socket

ISO/TS 21108:2005(E) Technical Specification specifies the dimensions and tolerances for the interface between impulse wrenches and their power sockets: output spindle of power tool - female drive end of power socket.

This interface is based on the principle of a socket centred on the cylindrical spindle.

Alternative dimensions and tolerances for two options, A and B, are provided.

It is applicable to both pneumatically and electrically driven impulse tools, and could also be used in other applications.

EYP series of oil pulse wrenches have been made according to above option "B",

therefore the power sockets made according to following Figure and Table

as specified per ISO/TS 21108:2005(E) are strongly recommended to be used together with EYP oil pulse wrenches.

Female drive end

The dimensions and tolerances for the female drive end of the power socket shall be in accordance with Figure and Table hereunder.

Figure — Dimensions and tolerances — Female drive end

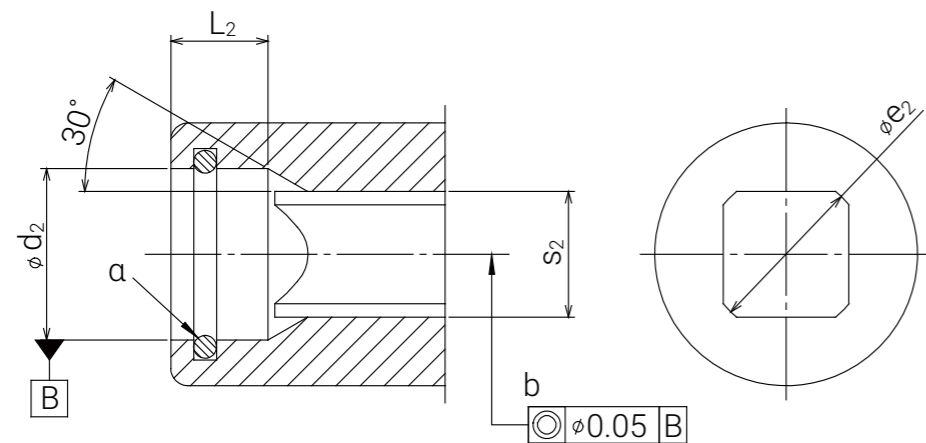

Key

- d_2 socket internal diameter
- e_2 diameter across square
- L_2 length of socket internal diameter
- s_2 width across flats of square
- a Rubber O-ring; may be used to take up the clearance to the male spindle.
- b Refers to centre of square.

Table — Dimensions and tolerances — Female drive end

Nominal square dimension	s_2^a		e_2^a	d_2 F8	L_2
	max.	min.	min.	Option B	0 -0.5
6.3	6.5	6.41	8.5	8.4	8
10	9.67	9.58	12.9	12	10
12.5	12.87	12.76	17.1	16	10
16	16.04	15.93	21.4	20	10
20	19.24	19.11	25.6	25	10
25	25.59	25.46	34.3	33	10

^a Dimension according to ISO 1174-2.



Message from the President

President
Yoshiaki Yoshimura

How to survive in the globalized economy?

With rapid advance in globalization of economy, the industrial world has been changing in pursuit of efficiency and growth. The way of business has been varied and growth sophisticated accordingly, and it becomes more and more difficult to have an appropriate outlook on the economic surroundings.

Years of experience or a rule of thumb used to work effectively, but such sense of values can not always be sufficient to foresee things in the business field. In order to survive in the competitive market place, it is required to review and have a different look at intercompany operating system and corporate organization which would be the same as always be. We, as Eisin personnel, will aim at realizing corporate progress and growth through effectively adapting ourselves to the changes in environment which new era dynamically generate. Feasibility study as well as research and development will be the most important role of Eisin, and these are to be the core functions to lead group companies of Toku to having ability to reform by themselves to keep up with the possible changes in the economic circumstances.



We will provide new values for the customers.

To give shape to corporate philosophy, we are working together with Toku Pneumatic Tool Manufacturing Company which is responsible for manufacturing and Toku Pneumatic Company which is responsible for sales, so that all of the corporate group efforts can be focussing on

the customers' satisfactions which, we believe, will only be the source of benefit we could expect to have.

Separated from Toku Pneumatic Tool Manufacturing Company, the engineering division handling designing and R&D and the sales & delivery division are now belonging to Eisin. This transference within the group companies is to define the role of each corporate body, furthermore aiming at growth and progress even if the state of world economy should not be in favourable environment.

To accomplish our aim, we will continually improve ourselves



to develop new products which will create new values and dig up potential demand in the market place. As for the sales, we expect much about the emerging countries like BRICs and the rising countries of Asia. Great deal of our sales efforts will be put into these areas under the new brand name of Eisin, providing new values for the market.

How to satisfy customers?

As a management concept, we declare a "customer oriented" policy. This is beyond the idea of, what is called, "customers' satisfaction". Our thought is that the source of our benefit comes from customers' satisfaction in every phase of our activities and communications with them. In other words, customers' satisfaction not only comes from their getting the visible values such as products or service, but comes from receiving invisible values like technical knowledge or good faith we present and as a result of their satisfaction, we could have considerations from them in return. Our principle is to have the customers satisfied with both visible and invisible values we are able to offer.

This corporate principle has been basically adopted in Toku Tool Manufacturing Company for many years. Based on this principle, we will accelerate the intercompany innovations, applying same to management control, sales training, market research and product development.

In order to achieve our highest goals, it should be inevitable to enhance quality of overall intelligence we could have and training program for personnel skillup. Capability to accurately analyze huge amount of information surrounded with us is most important, and in this sense we will strive for intercompany training to bring out sales staff and engineers having views from global viewpoint and innovation oriented consciousness. Succeeding Toku group companies from generation to generation is always our ongoing mission. Strong and steady steps to achieve our goals have been already taken.



EISIN CO.,LTD.

HEAD OFFICE :

6-1, Reizen-Machi, Hakata-Ku,
Fukuoka, 812-0039 Japan
Phone: 092-272-3541 Fax: 092-272-3539

SALES OPERATING CENTER :

5733, Minobaru, Miyaki-Machi, Miyaki-Gun,
Saga, 849-0102 Japan
Phone: 0942-94-9627 Fax: 0942-94-9628

www.eisin-tp.co.jp

Patent Numbers

U.S.A. : US7,032,685 B2
JAPAN : 第4008865号
CHINA : ZL200410058866.4
FRANCE : 1502707
SWEDEN : 1502707
GERMANY : 1502707